

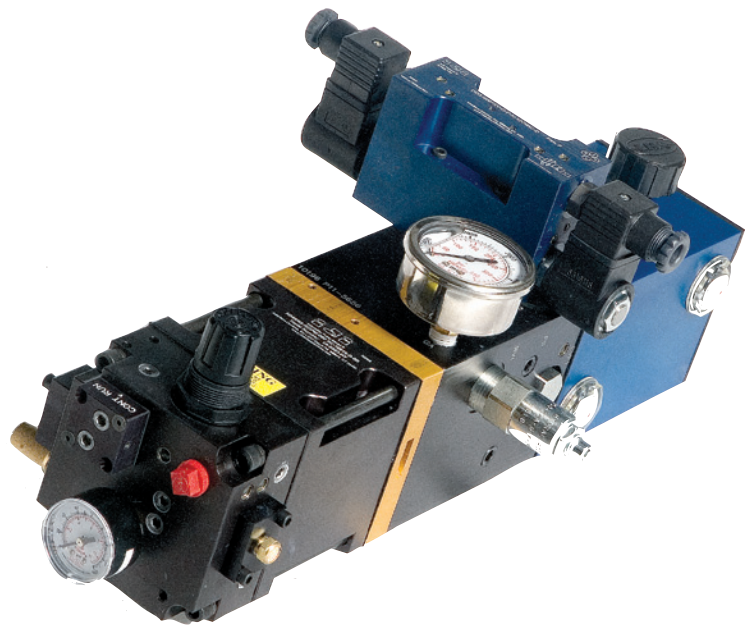

# E, H & P Series Air-driven Liquid Pumps

- Compact and Lightweight
- Horizontal or Vertical Mount
- No Regulator or Lubricator Required
- "Sparkless" Operation
- Integrated Circuit Design
- Aerospace Seals for Longer Life
- Limitless Circuit Options
- Maintains Pressure Without Energy Consumption
- Standard and Custom Configurations



**"Plug and Play" package for quick and simple installation**

**Power Workholding - Static Pressure Testing - Crimping - Tensioning**

**Pressing - Braking - Torquing - Compacting - Embossing - Milling/Calendering**

Interface Devices, Inc.

230 Depot Rd.

Milford, CT 06460

Tel: 203-878-4648 — Fax: 203-882-0885 — Toll Free: 800-539-0193

info@interfacedevices.com — www.interfacedevices.com

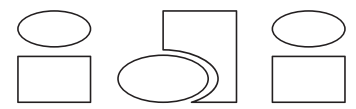

**Interface Devices, Inc.**

# E, H & P Series Air-driven Liquid Pumps

## Integrated Circuit Designs Available in Both Pneumatic & Hydraulic Sections

- **Lower Installed Cost**  
"Plug & Play" package – fewer materials and reduced labor to install and commission
- **Customized Circuits**  
Multiple hydraulic circuits can be integrated into a single package
- **Compact & Lightweight**  
Minimum wall or floor space required – ideal for portable applications

## Double Acting Operation

- **Energy Efficient**  
One-third less air consumption for the same output as a single-acting air-driven pump
- **Smoother Output**  
Power stroke in both directions reduces pulsations

## Double-acting Principle of Operation

Using compressed air as a power source, an air-driven liquid pump intensifies the hydraulic fluid by the ratio between the area of the air-drive piston and the area of the hydraulic piston. For example a 10:1 double-acting pump operates as follows:

### Pushing

Air at 100 psi (6.6 bar) enters the left air cylinder chamber and acts on a 10 sq. in. (65 sq. cm.) piston, pushing it to the right. The hydraulic piston is 2 sq. in. (13 sq. cm.) and the rod is 1 sq. in. (6.5 sq. cm). The crossover check valve allows oil to fill the rod end while discharging fluid to the outlet, the "push" ratio is based on the relationship between the air piston area and the hydraulic rod area, yielding an intensification ratio of 10:1.

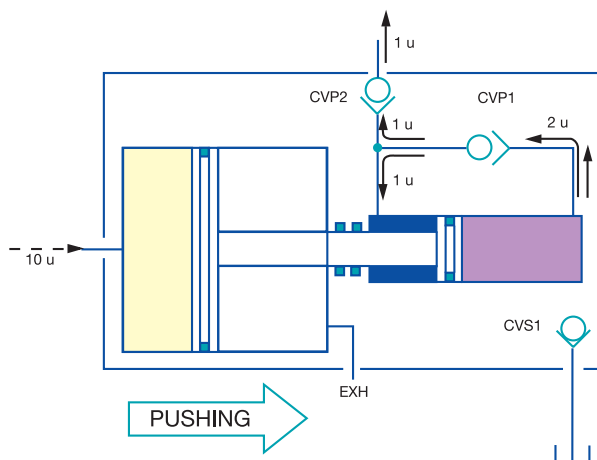

### Pulling

Air at 100 psi (6.6 bar) enters the right air cylinder chamber, pushing the air piston to the left (pulling the hydraulic piston). The "pull" ratio is also 10:1 as determined by the ratio of the areas of the air piston surface (less rod) to the hydraulic piston surface (less rod). Note during this stroke, oil is being drawn into the hydraulic piston end for the next "push" stroke.

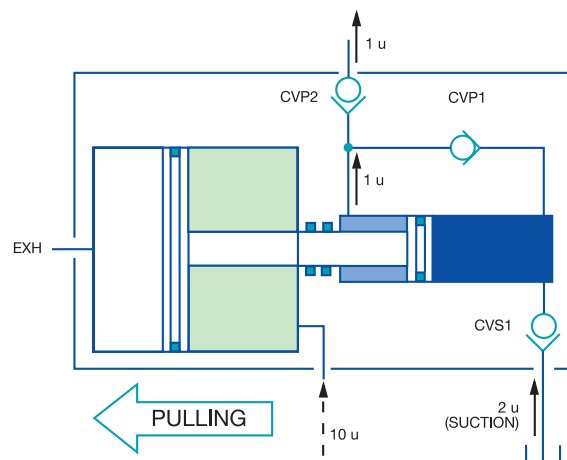

## Unique High/Low Dual Ratio Pumps

- **Low Ratio Mode**  
Move cylinder rapidly in either direction under light to moderate load
- **High Ratio Mode**  
Pump automatically shifts to high-pressure mode when resistance is met
- **Benefits**
  - Twin pump performance for the cost and size of one
  - Dramatically reduce air consumption while delivering faster cycle times

## Aerospace Piston & Rod Seals

- **High Efficiency**  
Low seal drag yields broader operating range
- **Prolonged Life**  
No metal-to-metal contact and no air lubrication required
- **No Fluid Migration**  
Twin seals with separator vent to isolate hydraulic and pneumatic sections



Interface Devices, Inc.

# E, H & P Series Air-driven Liquid Pumps

## E, H & P Series Power Output

E Series pumps have a peak hydraulic output of 1-1/3 HP (1 kW) at 2/3 of stall pressure. Maximum air consumption is 30 SCFM (850 LPM). Designed for fixed installation on standard 1-, 2- or 5-gallon (3.8-, 7.6- or 19-liter) reservoirs or on custom fabricated reservoirs, E-Series pumps are best suited for heavy-duty applications with large actuators.

P Series pumps have a peak hydraulic output of 0.9 HP (0.7 kW) at 2/3 of stall pressure. Maximum air consumption is 17 SCFM (482 LPM). The smaller P Series pumps come with self-contained reservoirs in sizes from 40 cu. in. to 160 cu. in. (0.7 to 2.6 L) and are ideally suited for portable operation, or for medium to small actuators.

H Series pumps are ideally suited for in-between applications requiring higher flows than the P Series while maintaining a smaller footprint than the E Series. H Series pumps have more circuit options than the P Series and lower air consumption than the E Series.

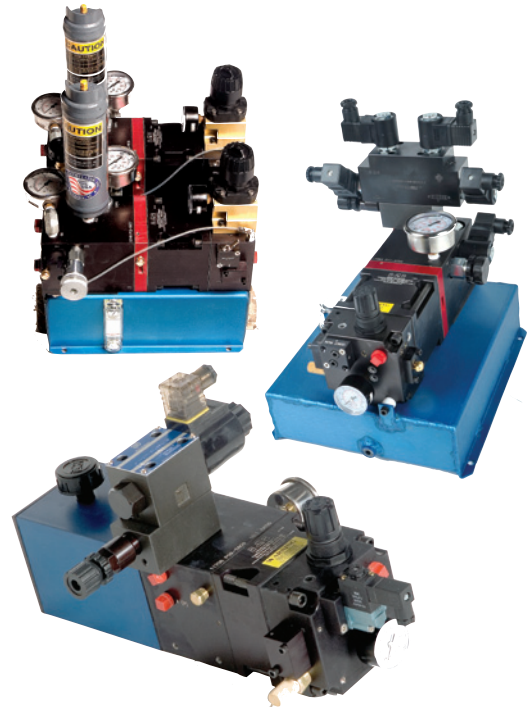

## Applications

Air-driven Liquid Pumps are ideally suited for intermittent pressure/flow applications and offer the following benefits:

- Removes the costs and complexities of pressure-compensated variable-volume pumps
- Unlike electric driven pumps, consumes no energy upon achieving and maintaining hydraulic pressure
- Sparkless operation is suitable for explosion-proof areas without any special modification
- Emergency and remote operations using SCBA or nitrogen bottles
- Optional custom designs including multi-pump systems and turn-key packages

# E, H & P Series Air-driven Liquid Pumps

## Pump Model Code & Selection

Because E, H & P Series Air-driven Liquid Pumps can be customized in almost limitless ways, it is important to define the specific application and components to be used:

- Pressure required
- Single- or double-acting cylinders
- Volume of oil required
- Extension/retraction speed required
- Number of cycles per minute, hour or day
- Fluid to be used
- Number of hydraulic circuits
- Type of valves being used
- Control methods of pump
- Available air volume and pressure
- Size limits and space requirements
- Required accessories

## E, H & P Series Specifications

Maximum inlet air pressure of 125 psi (8.5 bar). Hydraulic output pressures from 100 to 10,000 psi (6.8 to 680 bar). Minimum connected air pressure of 50 psi (3.4 bar). "Pull Ratio/Push Ratio" designates pump model.

<b>Single-Acting:</b>		<b>Double-Acting:</b>		<b>Dual Ratio Models:</b>
Ratio	Model	Ratio	Model	
5:1	000/05	10:1	010/10	060/10
60:1	060/00	20:1	020/20	045/20
75:1	075/00	30:1	030/30	060/20
100:1	100/00	45:1	045/45	075/20
				100/20
				175/20

*Custom ratios available upon request*

## Standard Model Options

<b>Regulator:</b>	R = included, 0 = No Regulator
<b>Air Gauge:</b>	G = included, 0 = No Gauge
<b>Mufflers:</b>	PM = Plain Muffler, QM = Quiet Muffler
<b>Reservoirs:</b>	NRS = No Reservoir
	1GA BA = 1 Gallon Aluminum Tank, Blue Anodized
	2GA BA = 2 Gallon, 5GA BA = 5 Gallon
	040 SC = 40 cu. in. Self-Contained
	060 SC = 60 cu. in., also 080 SC, 120 SC and 160 SC
	040 SA = 40 cu. in. Sealed, All Attitude
<b>Hydr. Valves:</b>	Number indicates how many of each valve cavities/pads
<b>Seals:</b>	B = Buna, V = Viton, E = EPR
<b>Accessories:</b>	00 = None, AO = Air Only, OB = Hydraulic Only, AB = Both



**Interface Devices, Inc.**

# E, H & P Series Air-driven Liquid Pumps

## Model Code Example

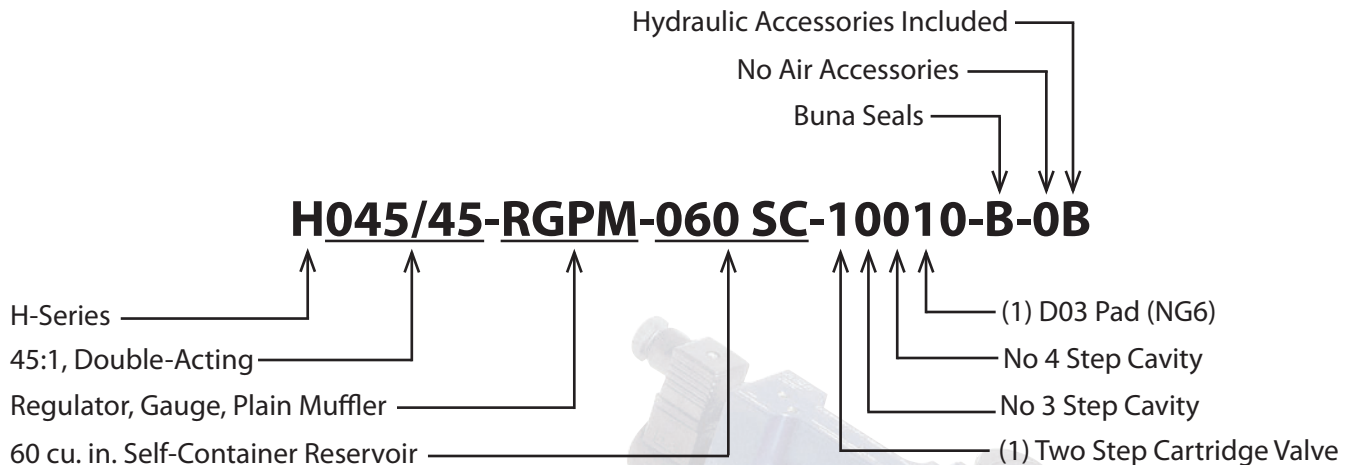

Note: In this case, the Two-Step Valve may be a Relief or Needle Valve. The D03 (NG6) pad is for standard subplate mounted valves and modules. The indicated accessory alerts not part of the main model code are listed below.

## Typical Accessories

### Pneumatic Accessories (Alert Code "A")

Proportional Regulator  
 Manual or Auto-Drain Air Filter  
 Glycerin Filled Gauge  
 ON/OFF Valve (Manual or Solenoid)  
 60 psi Regulator Spring  
 OSHA Shut-off valve

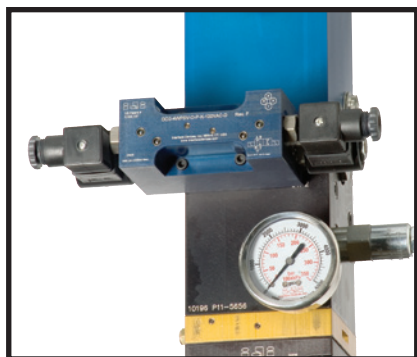

### Hydraulic Accessories (Alert Code "B")

Zero Leak Dump Valve (Normally Open or Closed)  
 Relief Valve  
 Pilot-Operated Check Valve  
 3-Way Cartridge Solenoid Valve  
 Proportional Valves  
 3- or 4-Way D03 Valve (All Configurations)  
 D03 Modular (Sandwich) Valves  
 Pressure Reducing Valve  
 Flow Control Valve  
 Gauges  
 Filter  
 Accumulator  
 Pressure Switch or Transducer  
 Customer Specified Hydraulic Ports (SAE, BSP, etc.)  
 Misc. Others – Consult Factory

# E, H & P Series Air-driven Liquid Pumps

Single-Acting Models

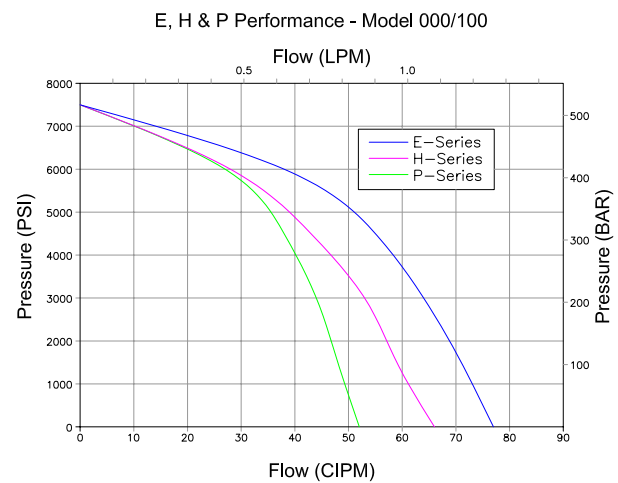
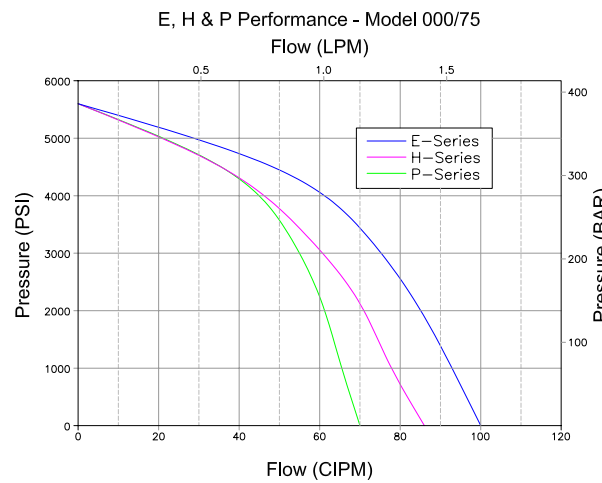
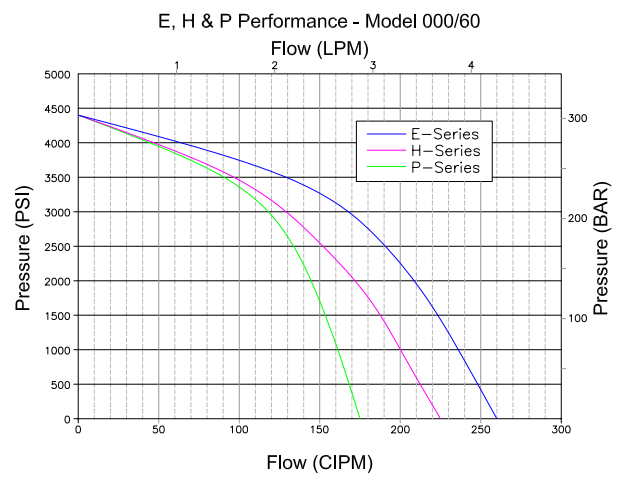
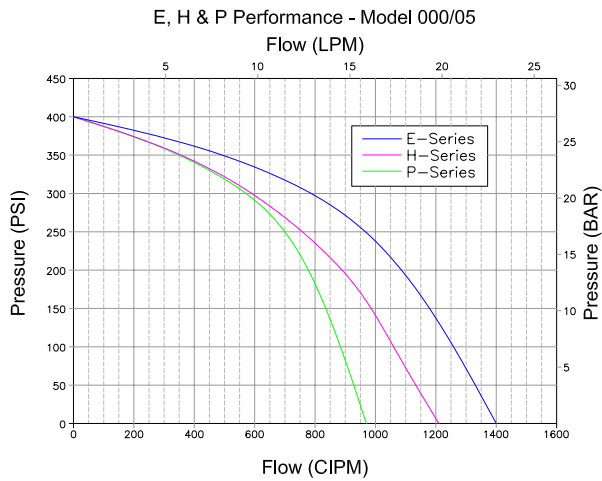

Double-Acting Models

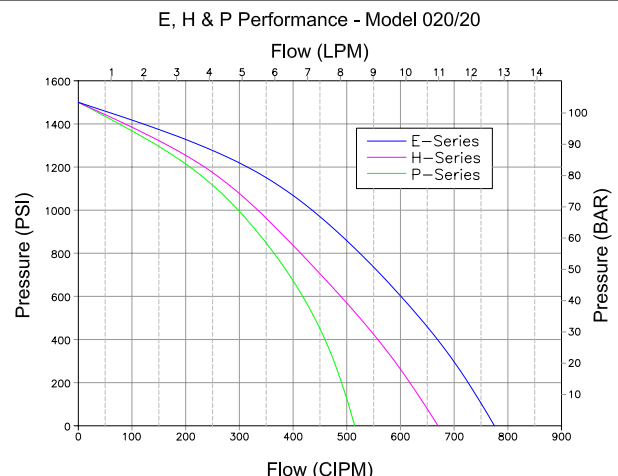
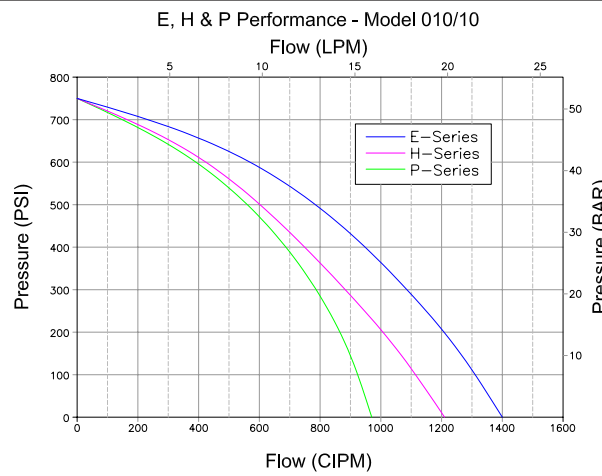

Interface Devices, Inc.

# E, H & P Series Air-driven Liquid Pumps

Double-Acting Models

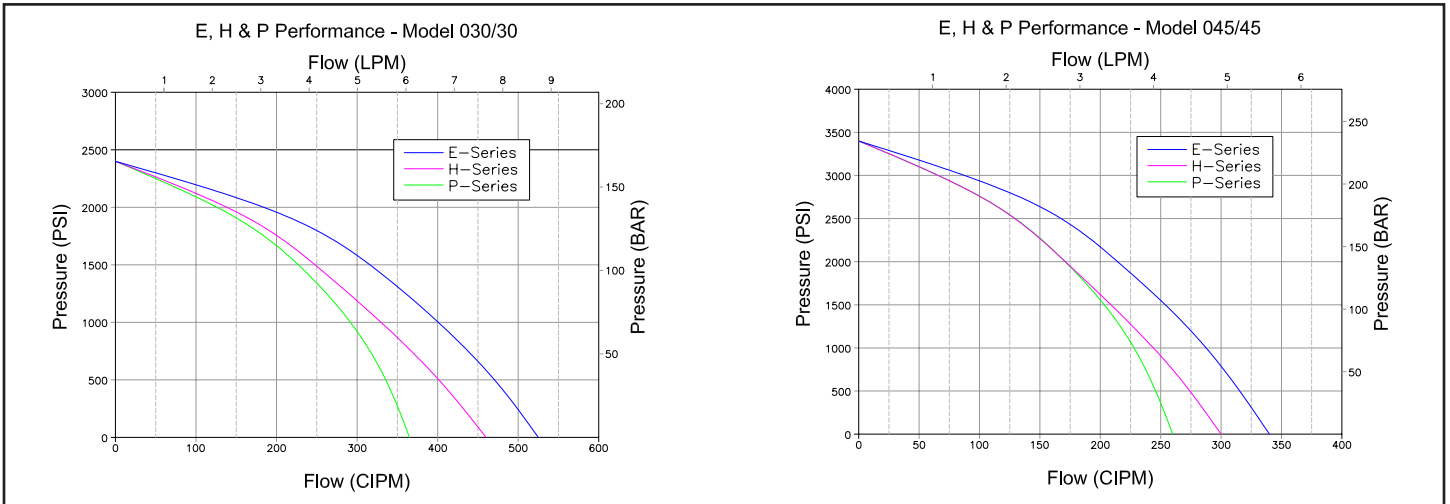

Dual Ratio Models

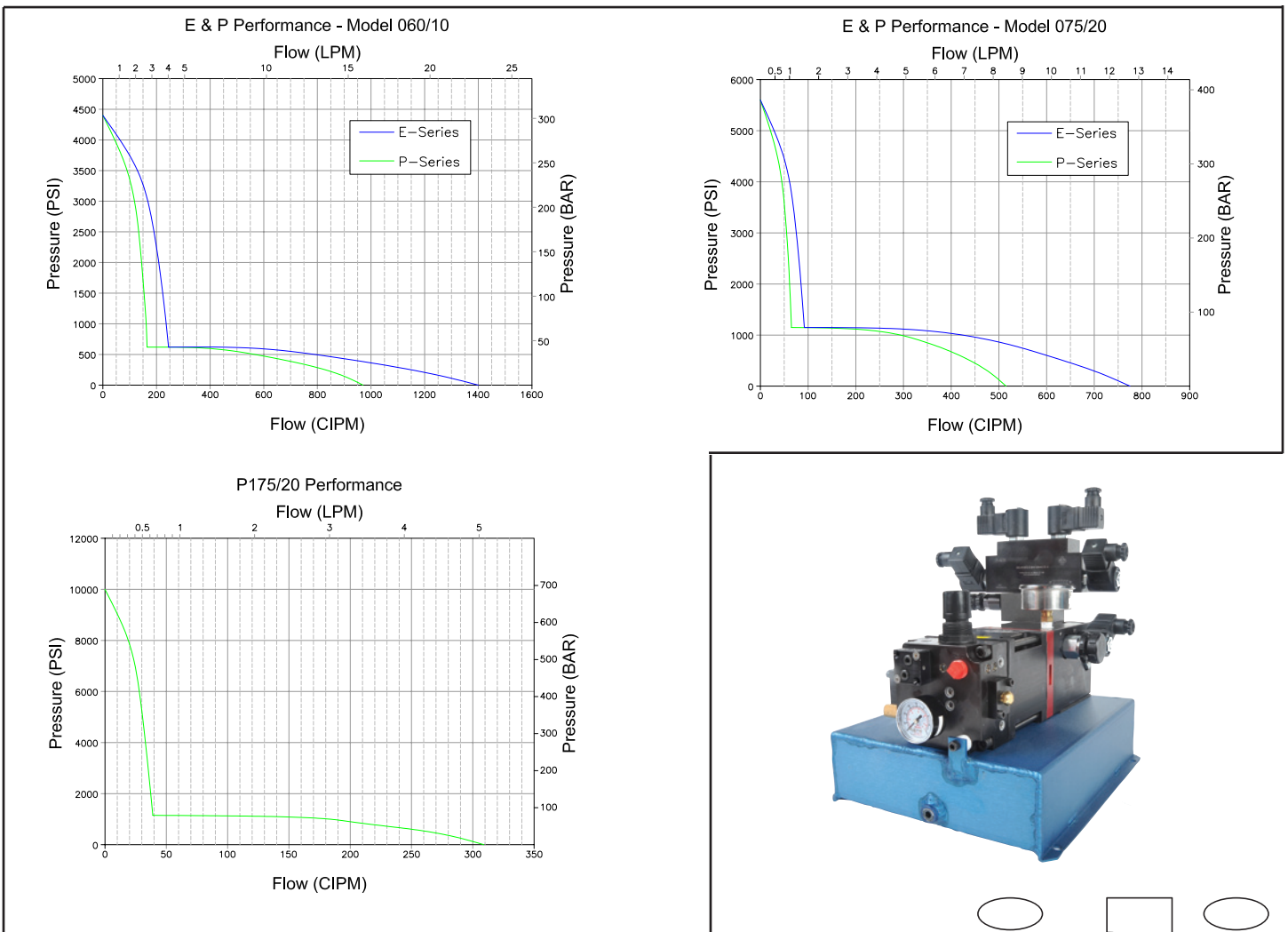

Interface Devices, Inc.

# DIMENSIONAL INFORMATION

## E-Series

Interface Devices, Inc.

230 Depot Rd.

Milford, CT 06460

Tel: 203-878-4648 — Fax: 203-882-0885 — Toll Free: 800-539-0193

info@interfacedevices.com — www.interfacedevices.com

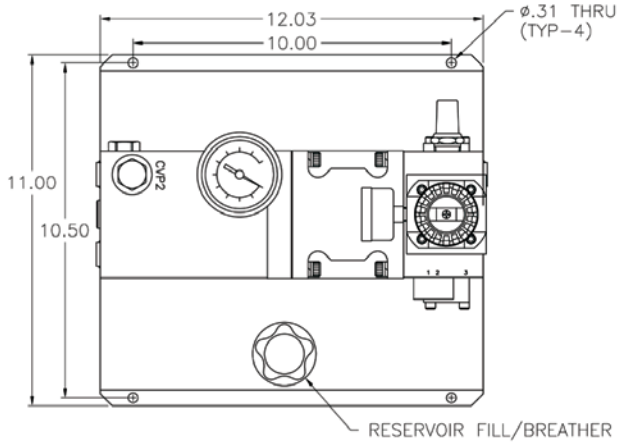

RESERVOIR	H	h
1 GAL	12.6	3.25
2 GAL	14.6	5.25
5 GAL	20.6	11.25

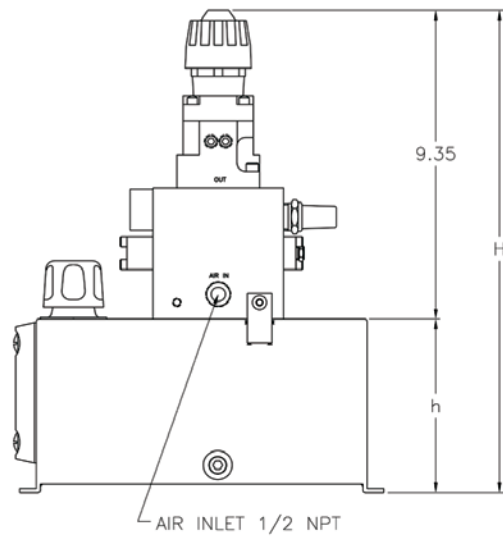
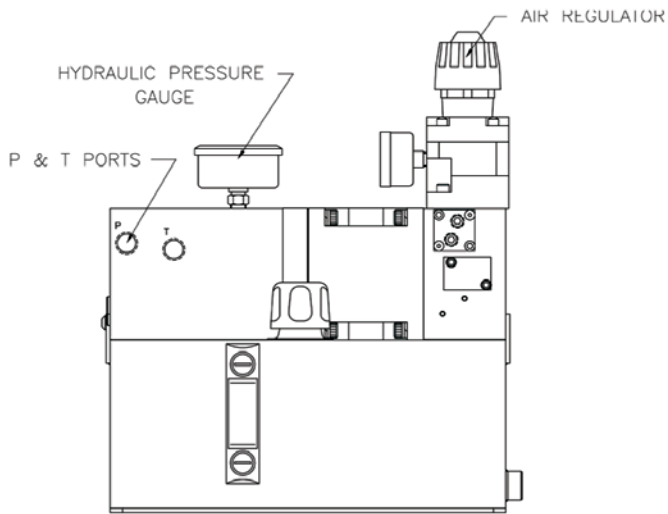

## H & P Series

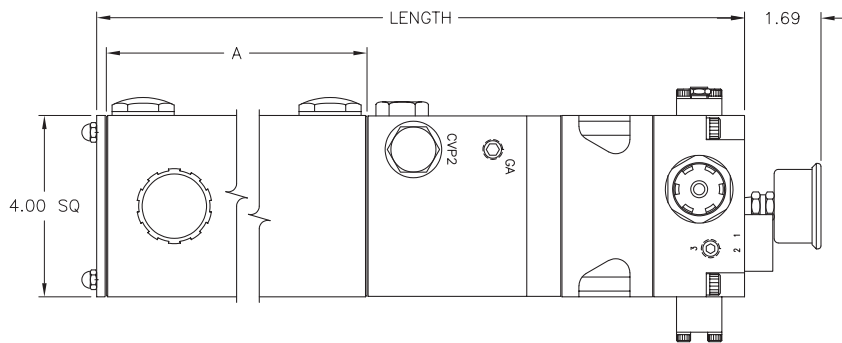

VOLUME (CU IN)	"A"	LENGTH
20	1.50	10.04
40	3.00	11.54
60	4.50	13.04
80	5.75	14.29
100	7.25	15.79
120	8.75	17.29
160	11.50	20.04

