

NOTES

- 1 RECOMMENDED SPARES ITEM: SEAL KIT
- 2 RECOMMENDED SPARES ITEM: OTHER
- 3 LIGHTLY APPLY ITEM 22 "GREASE" TO ALL SEALS AND MATING PARTS AT ASSEMBLY

REV	DESCRIPTION	DATE
B	PICTURE CHANGE ITEM 6; ITM 11 QTY WAS 2, P/N WAS SO-006CN7; ADDED NEW P/N'S	11/21/00
C	ADDED 29 & 30; PICTURE CHANGE ITEM 6	10/23/02
D	PIC CHG ITEM 48; DEL 41,43,44,46,47,49	4/14/11

30	1	11753	TEFLON B'UP RING, -012	
29	1	SO-012P7	O-RING	
28	2	11772	DOWEL PIN, Ø3/16 X .62	
1	27	5	SO-011B7	O-RING
26	REF	P10-14XX	RATIO PLATE ASSY	
25	1	10112 P12-5201	BODY, AIR CYLINDER	
1	24	2	10334 P00-5205	GASKET, AIR BODY
23	2	10-24 x 1	SCREW, SOC HD CAP	
22	A/R	11953	GREASE, WHT LITHIUM	
21	4	5/16-18 x 4.50	SCREW, SOC HD CAP	
20	4	10393	LOCK WASHER, 5/16	
2	19	1	10016 P10-1202	AIR REG ASSY
18	REF	10342	GAUGE, AIR (0-160 PSI)	
17	4	1/4-20 x 1.00	SCREW, SOC HD CAP	
16	4	10392	LOCK WASHER, 1/4	
15	1	11768 P00-1202	CAP ASSY, PILOT	
14	1	10264	BREATHER, 1/8 NPT	
13	1	10431	MUFFLER, 3/8	
1	12	1	SO-111B7	O-RING
1	11	1	SO-006B7	O-RING

10	1	10006 P10-5201	HSG, AIR CAP	
9	1	10299 P00-5208	CAP, SPOOL	
8	1	10271 P00-5212	BUSHING, SHORT	
7	1	10269 P00-5210	BUSHING, LONG	
2	6	10659 P00-5211	SPOOL, AIR VALVE	
1	5	6	10629	TEE SEAL
4	5	10273 P00-5209	CAGE	
1	3	1	SO-019B7	O-RING
2	2	10-24 x .62	SCREW, SOC HD CAP	
2	1	10017 V04-1005	AIR VLV ASSY, 2-WAY	

ITEM	QTY	PART NUMBER	DESCRIPTION
			INTERFACE DEVICES, INC. 230 DEPOT ROAD MILFORD, CT 06460
SCALE: HALF		TITLE: ASSEMBLY, P SERIES PUMP	
DWN BY: WNI		REF:	
DATE: 5/26/98		REF:	
SHT: 1 OF: 2		DWG NO: MPXXX/XX-RGPM	REV: D

REV	DESCRIPTION	BY	DATE
C	ADDED 29 & 30; PICTURE CHANGE ITEM 6	WNI	10/23/02
D	PIC CHG ITEM 48; DEL 41,43,44,46,47,49	WNI	4/14/11

NOTES

1 PORT 3 IS COMMON TO PORT 2.
CONNECT PORT 3 TO REMOTE AIR PILOT OPERATED
HYDRAULIC RELEASE VALVE

2 MOUNTING SCREWS AND GASKET/O-RINGS ARE
FURNISHED FOR EACH OPTION

3 ROTATE ADAPTER BLOCK TO MATCH "V" STAMPED ON AIR CAP
FOR THE DESIRED FUNCTION

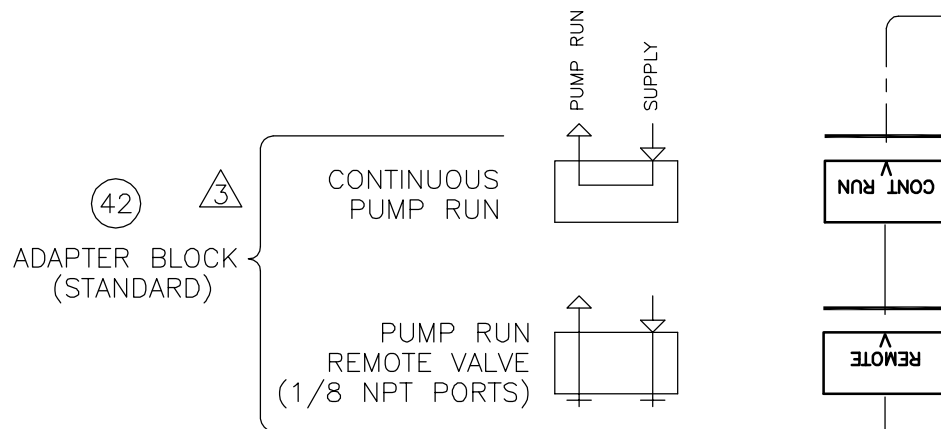
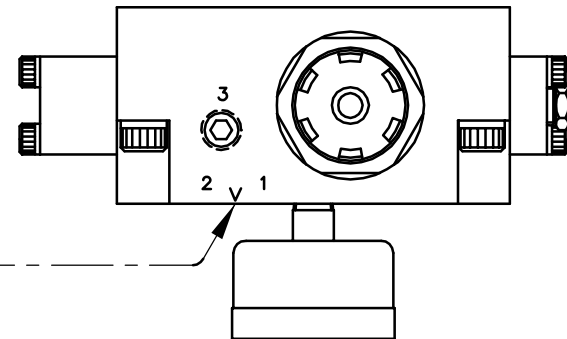

VOLTAGE	ITEM 57 P/N
24 VDC	11837 V04-1003
120 VAC	11838 V04-1003
240 VAC	11919 V04-1003

45 LOCAL MANUAL VALVE
(OPTION)

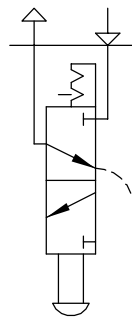

48 LOCAL SOLENOID VALVE
(OPTION)

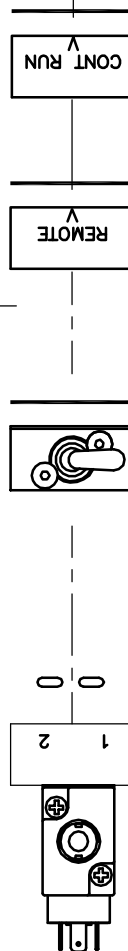
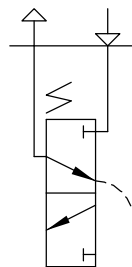

50			
49			
48	REF	SEE CHART	SOL AIR VALVE ASSY
47			
46			
45	REF	10449 V04-1002	MAN TOGGLE SWITCH ASSY
44			
43			
42	REF	11235 P00-1206	BLOCK ASSY, ADAPTER
41			

ITEM	QTY	PART NUMBER	DESCRIPTION
INTERFACE DEVICES, INC. 230 DEPOT ROAD MILFORD, CT 06460			
SCALE: HALF		TITLE: ASSEMBLY, P SERIES PUMP	
DWN BY: WNI			
DATE: 5/26/98		REF:	
SHT: 2	OF: 2	DWG NO: MPXXX/XX-RGPM	REV: D