

VOLUME (CU IN)	OAL	L
40	12.80	3.00
60	14.30	4.50
80	15.55	5.75
100	17.05	7.25
120	18.55	8.75
160	21.30	11.50

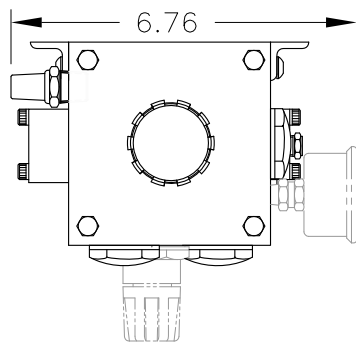

REV	DESCRIPTION	BY	DATE
-	-	-	-

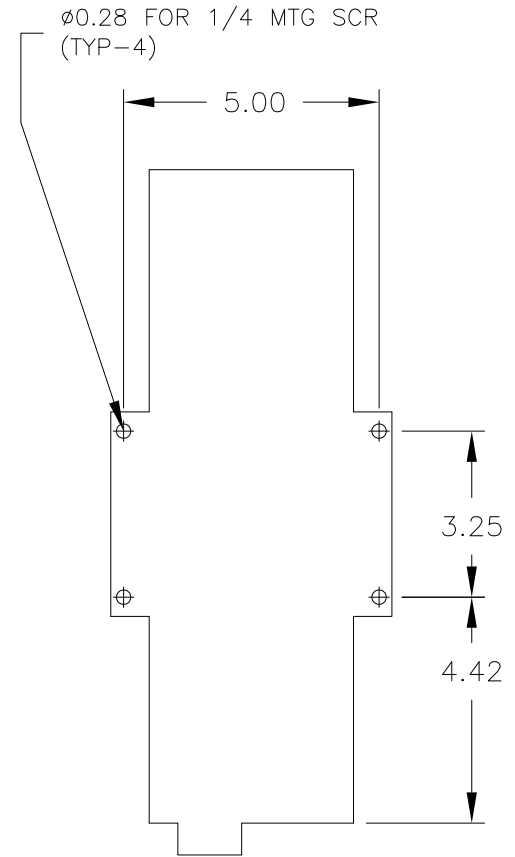
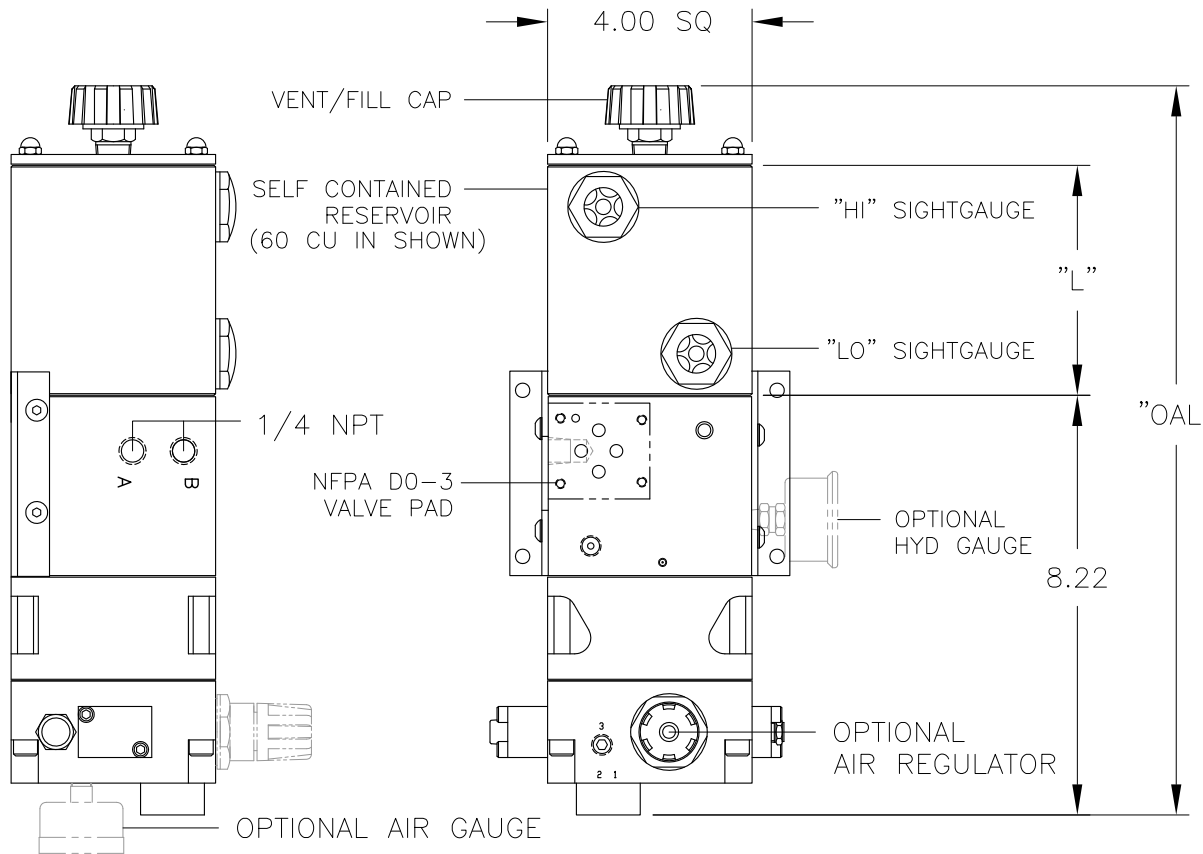

MOUNTING DIMENSIONS

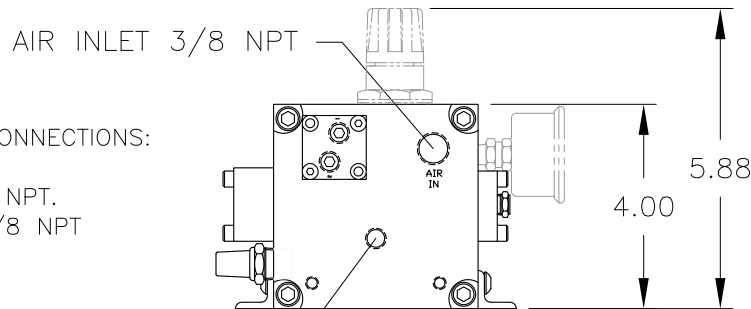

PNEUMATIC & HYDRAULIC CONNECTIONS:
 "AIR IN" PORTS: 3/8 NPT
 "A" & "B" CYL PORTS: 1/4 NPT.
 AIR & HYD "GA" PORTS: 1/8 NPT

AIR GAUGE PORT 1/8 NPT

		INTERFACE DEVICES, INC. 230 DEPOT ROAD MILFORD, CT 06460	
SCALE: 1/4	TITLE: GENERAL ARRANGEMENT, TASQ SERIES PUMP SELF CONTAINED RESERVOIR		
DWN BY: WNI	REF: Integral Air Regulator		
DATE: 10/11/06	DWG NO: P09-0007		REV: -
SHT: 1 OF: 1			