

**NB/NBR NITROGEN BOOSTER
FOR AVIATION SERVICE**

**INSTALLATION, OPERATION
& MAINTENANCE MANUAL**

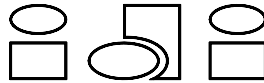

INTERFACE DEVICES, INC. 230 Depot Road, Milford, CT 06460
Ph: (203) 878-4648, Fx: (203) 882-0885, E-mail: info@interfacedevices.com
www.interfacedevices.com

**IMPORTANT! FILE THIS MANUAL IN A SAFE PLACE FOR FUTURE SERVICE & PARTS NEEDS
ALWAYS REFERENCE THE SERIAL NUMBER FOR SERVICE & PARTS REQUESTS**

Safety instructions specifically pertaining to this unit appear throughout this manual highlighted by these signal words ** Warning**** and ****Caution**** to denote different levels of hazard.**

Warning: denotes practices, which if not carefully followed, could result in property damage, **SERIOUS** personal injury and /or **DEATH**

Caution: denotes practices which if not carefully followed, could result in minor personal injury or damage to equipment.

NB(R) Serial Number: _____

STATEMENT OF WARRANTY

Interface Devices, Inc. (IDI) warrants its products to be free from defects in material and workmanship under normal use and service for a period of one (1) year from date of shipment. Any defect discovered after the warranty period has expired will be deemed to be outside the above coverage. No goods claimed to be under warranty shall be accepted for return unless authorized by IDI.

Upon discovery of a defect (other than freight damage) or a shortage of an item received in the original shipping container, the purchaser shall, within (10) calendar days, deliver notice of the defect or shortage. Damaged freight claims must be placed with the freight carrier and will not be honored by IDI. If after due investigation of a claim of defect or shortage is found valid, IDI, at its sole discretion, may discharge its entire obligations to the purchaser by either repair or replacement of the defective product or component and for shortages by furnishing a replacement of the missing quantity.

This express warranty supersedes and is in lieu of all other remedies and warranties, including the implied warranties of merchantability and fitness for a particular purpose, and liability for negligence. **IN NO EVENT SHALL IDI BE LIABLE FOR INCIDENTAL OR CONSEQUENTIAL LOSSES, EXPENSES OR DAMAGES INCLUDING DAMAGES FOR PERSONAL INJURY OR COMMERCIAL LOSS.**

Table of Contents

| | | |
|------------|---|-----------|
| 1 | General Description | 1 |
| 2 | Specifications / Features | 2 |
| 2.1 | Component Description | 3 |
| 3 | Preparation for use | 4 |
| 3.1 | Safety Instructions..... | 4 |
| 3.2 | General Safety Precautions | 4 |
| 3.3 | Assembly | 5 |
| 4 | Operation | 6 |
| 4.1 | Preparation for Operation..... | 6 |
| 4.2 | Charging the Nitrogen System | 6 |
| 4.3 | Disconnecting Nitrogen Booster | 7 |
| 5 | Maintenance | 8 |
| 5.1 | General..... | 8 |
| 5.2 | Storage..... | 8 |
| 6 | Troubleshooting | 9 |
| | Drawings and Schematics..... | 10 |

1 General Description



NB(R) –

The ENB 45 Pneumatic Nitrogen Booster provides the capability of boosting remaining lower pressure Nitrogen from supply bottles to the required pressure, from 400 to 4,500 psi.

The Nitrogen Booster is driven by compressed air or nitrogen. It cycles automatically to boost low-pressure nitrogen to high pressure.

**** Warning ****

To Avoid Serious Injury, Loss of Limb or Death

1. Use of a supply Bottle pressure regulator is required with this unit.
2. **Do not** try to boost any gas other than nitrogen
3. **Do not** exceed 3000 PSIG inlet Pressure.
4. All Components used in the nitrogen system or shop air system shall be clean, dry and free of all contamination.
5. Servicing and/or maintenance of nitrogen systems shall be done by trained and qualified personnel using approved procedures per SAE specifications.

2 Specifications / Features

Dimensions: 12.1" long, 9.4" high and 10.8" wide.

Weight: 24lbs. complete.

Output Rating: Adjustable from 500 to 4500 psi.

Nitrogen Booster Ratios: 20:1, 30:1 or 45:1.

INTERFACE DEVICES INC
-NITROGEN BOOSTER NB(R)

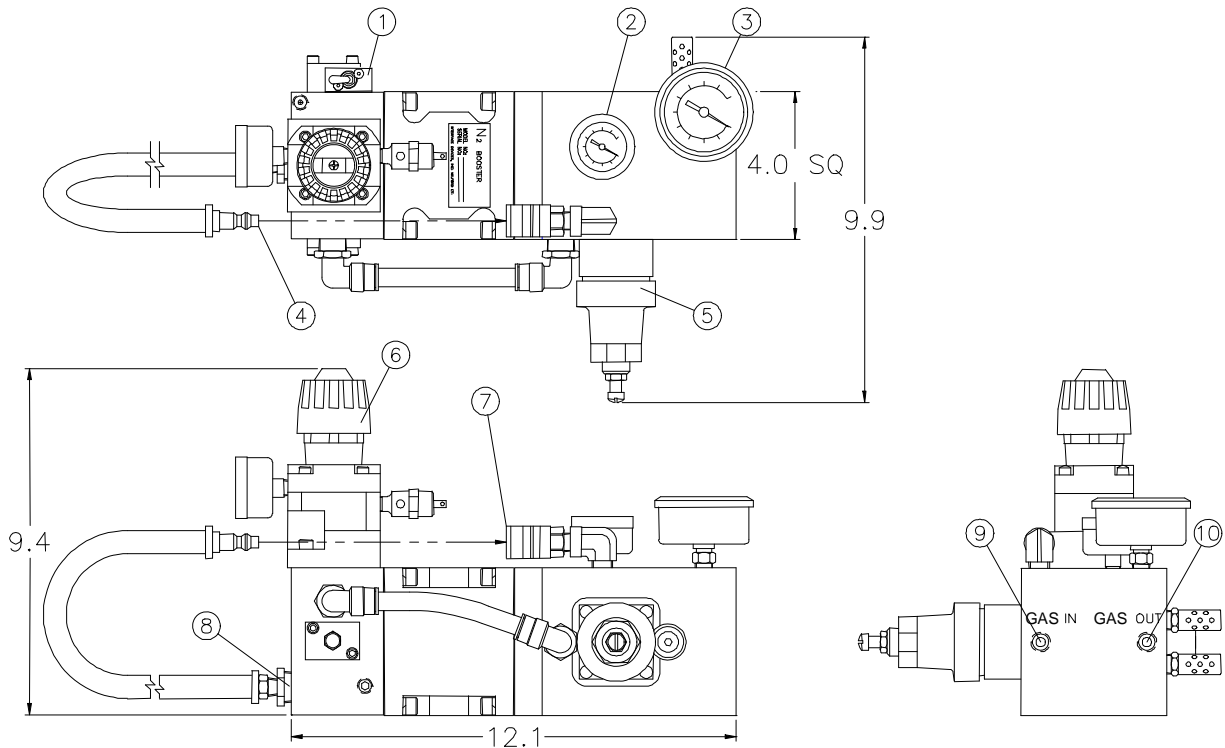

Fig. 1

2.1 Component Description

(Refer to Fig. 1 for component locations)

1. Pump on / off Air Switch.
2. Nitrogen Drive Pressure Gauge.
3. Nitrogen out Pressure Gauge.
4. Air or Nitrogen in Male Quick Connector half.
5. High Pressure Nitrogen Supercharge Regulator.
(Factory set to 125 PSIG)
6. Air/Nitrogen Regulator & gauge .
(Sets N₂ Boost Pressure, (ie: 80 PSIG in yields 3,600 psi N₂ Out).
7. Female Quick Disconnect Half (used when driving with nitrogen).
8. Air Inlet (1/2 npt, reference).
9. Gas In Port: 1/4 npt 3,000 psi max..
10. Gas Out Port: 1/4 npt, 400 to 4,500 psi max.

Typical Applications: Emergency gear blow-down bottle, hydraulic accumulator pre-charge, landing gear struts.

3 Preparation for use

**** Caution ****

It is mandatory that this instruction manual be read, understood and followed by all persons operating this high- pressure nitrogen booster.

3.1 Safety Instructions

- 3.1.1 General: Information presented in this manual and on various labels, tags and plates on the unit pertains to equipment design, installation, operation maintenance and trouble shooting which should be read, understood and followed for safe and effective use of this equipment.
- 3.1.2 Safety: The operation, maintenance, and trouble shooting of this high pressure Nitrogen Booster requires practices and procedures which ensure personal operator safety and the safety of others. Therefore, this equipment is to be operated and maintained only by qualified persons in accordance with this manual and all applicable local codes.
- 3.1.3 Safety instructions specifically pertaining to this unit appear throughout this manual highlighted by these signal words ****Warning**** and ****Caution**** to denote different levels of hazard.
****Warning**** denotes practices which if not carefully followed, could result in SERIOUS personal injury and /or DEATH.
****Caution**** denotes practices which if not carefully followed, could result in minor personal injury or damage to this equipment.
- 3.1.4 Training: Read through this entire manual prior to any Nitrogen booster operation. All personnel using this Nitrogen Booster should understand and follow this manual and receive training. We encourage our customers to call Interface Devices to discuss any operating or testing requirements.

3.2 General Safety Precautions

- 3.2.1 Pressures: Gasses under pressure are a potential hazard in the form of stored energy. Accidents can occur when this energy is improperly handled. Be sure that all equipment used is compatible and designed to control the pressures encountered.
- 3.2.2 Nitrogen: Nitrogen is a stable gas and non-flammable.
- 3.2.3 Lubrication: the use of lubrication in a Nitrogen system should be kept to a minimum. The booster requires no lubrication. An air line lubricator must not be used.

**** Warning ****

Only Lubricants compatible with high-pressure nitrogen shall be used

No lubricant shall be applied in any area that will come into direct contact with Nitrogen during normal use.

3.3 Assembly

- 3.3.1 Although the Nitrogen Booster is inspected prior to shipping, it could be damaged during shipping. Therefore, it should be carefully unpacked and placed on a clean level surface for inspection.
- 3.3.2 The Nitrogen booster is furnished with three 1/4-20 by 1/2" deep tapped holes for mounting to a bracket or cart.
- 3.3.3 Customer supplied parts:
- Two AN816-6, 3/8" AN to 1/4" male pipe adapters.
 - Two stainless steel/Teflon® -6 hose assemblies, rated to 5,000 psi working pressure.
 - Teflon® pipe tape.
 - Pressurization attachment fitting.
- 3.3.4 Wrap 2-3 turns of Teflon® tape clockwise around the 1/4" pipe thread ends of each adapter fitting.

**** Caution ****

The customer supplied nitrogen supply must be complete with shutoff valves, pressure gauges, pressure regulators and -6 hose assemblies. These components must be rated for 5,000 psi operation.

- 3.3.5 Remove the protective plastic plugs from "GAS IN" and "GAS OUT" ports.
- 3.3.6 Insert 1/4" nipple ends into their respective ports, and firmly tighten down, being careful not to over-tighten. With supply regulator closed, connect one -6 swivel hose end to the "GAS IN" fitting. Connect the other hose to the "GAS OUT" port.

- 3.3.7 Attach the pressurization fitting to the other end of the nitrogen out hose.
- 3.3.8 Check all components for integrity. If all is well, you are ready to use NB(R) Booster.

4 Operation

4.1 Preparation for Operation

- 4.1.1 Be sure all valves and controls are in the closed position.
- 4.1.2 Decrease the item 6 (fig 1) inlet pressure regulator to its minimum pressure setting.
- 4.1.3 Inspect all connections for contaminants before installation and tightening. Remove any foreign Materials. Be sure all Nitrogen components are clean as per SAE specifications.
- 4.1.4 Connect the output of the gas supply bottle to the “GAS IN” connection of the booster (see figure 1a).
- 4.1.5 Decrease the nitrogen bottle regulator to its minimum pressure setting.
- 4.1.6 Connect the Nitrogen fill line and purge line by SLOWLY cracking open gas supply bottle shutoff valve and adjusting the supply bottle pressure to a low-pressure setting.

**** Warning ****

Be sure fill line is secured prior to purging the unit. This will prevent the hose from whipping about if too much N₂ is allowed to flow through the unit

- 4.1.7 Tighten the N₂ fill line connection.
- 4.1.8 The high pressure N₂ Booster is ready to charge the system.

4.2 Charging the Nitrogen System

**** Warning ****

When nitrogen line is pressurized or when nitrogen is flowing through the system, the fill line hose may “whip” about if not secured.

INTERFACE DEVICES INC
- NITROGEN BOOSTER NB(R)

- 4.2.1 After the nitrogen booster has been properly connected, fully open the N₂ supply bottle shut off valve. Adjust the gas supply bottle pressure regulator to the required N₂ system Pressure. Wait until the bottle pressure and the system pressure are equal. If the supply bottle pressure is lower than the required system pressure, run the booster as follows:
- 4.2.2 Adjust the booster's air pressure to attain a pressure slightly lower than the final required N₂ pressure (divide this nitrogen pressure by the pump ratio to find the initial required regulated air pressure setting). Example for ENB-45: 3,000 psi final pressure minus 75 equals 2,925 psi divided by 45 equals 65 psi regulated air pressure.
- 4.2.3 Turn on the booster's "PUMP RUN" toggle switch to the "ON" position to further pressurize the nitrogen system. The nitrogen outlet pressure gauge will show the system pressure developed by the booster. When the set pressure has been reached (i.e.: pump stops pumping), increase the pressure of the air regulator to obtain the required final system pressure. When the booster stops running, turn off the booster by switching the toggle switch to the "OFF" position.

4.3 Disconnecting Nitrogen Booster

- 4.3.1 Close the nitrogen bottle shut off valve. This will stop inlet nitrogen flow.
- 4.3.2 Decrease both the air inlet pressure regulator and the nitrogen supply bottle pressure regulators to their respective minimum settings.
- 4.3.3 Disconnect air (or nitrogen) supply line.
- 4.3.4 Slowly loosen, bleed down, and disconnect nitrogen fill line. Disconnect the supply hose.
- 4.3.5 Cap both hose connections to prevent nitrogen hoses and booster contamination.

5 Maintenance

**** Warning ****

Maintenance should be undertaken by qualified personnel only.

The operation, maintenance and troubleshooting of this high pressure Nitrogen Booster system requires practices and procedures which ensure personal operator safety and the safety of others. Therefore, this equipment is to be operated and maintained only by qualified persons in accordance with this manual and all applicable codes.

5.1 General

- 5.1.1 All maintenance performed on this high pressure Nitrogen Booster shall be conducted in accordance with all applicable codes governing the handling, operation, installation and trouble shooting for high-pressure gas operation. Maintenance is to only be done by qualified persons.
- 5.1.2 All maintenance personnel must be familiar with the cautions and warnings associated with high pressure gas systems as outlined in sections 3.1 and 3.2 of this manual prior to performing any maintenance on this unit.
- 5.1.3 The gauges on this unit should be inspected and calibrated annually to $\pm 1/2$ % of full scale, to maintain and ensure accuracy.

5.2 Storage

- 5.2.1 Store the unit in a clean, dry and secure area when not in use.
- 5.2.2 Be sure all hoses are capped and the unit is covered with a lint free covering for the duration of unit storage to ensure complete N₂ system cleanliness for future system recharging.

6 Troubleshooting

**** Warning ****

Troubleshooting should be undertaken by qualified personnel only.

Troubleshooting Chart

| Symptom | Probable Cause | Remedy |
|---|---|--|
| Pump will not cycle (Only regulated nitrogen pressure at out put.) | No air supply to pump Pump regulator set too low Four way air reciprocating valve spool stuck at mid position | Look for and fix Increase setting Disconnect/ reconnect air supply (resets air spool to end position) If spool still sticks, manually push spool to far end with probe through hole in “spool stop cap”. If stuck or requires excessive force, disassemble air valve assembly. Inspect for contamination or mechanical bind. Repair or replace, lubricate seals with water-proof grease |
| Pump makes one cycle then stops | Faulty “2 way air Valve” (Broken, leaks or contaminated) | Repair or replace |
| Pump cycles constantly when Dead Headed | External leak at pump or down stream high pressure circuit Contaminated or stuck open check valve cartridge Internal leak in pump | Look for and correct Clean or replace Check all dynamic and static seals and gaskets |

| REV | DESCRIPTION | DATE |
|-----|---|---------|
| A | ADDED 125 PSI "RV". AIR CIRCUIT TO S.A. | 1/9/03 |
| B | CYL R.E. EXHAUST COMMON TO H.E. EXHAUST | 4/11/03 |
| C | RELABELED PORTS | 1/26/07 |

PUMP ON/OFF
MANUAL "TOGGLE" VALVE

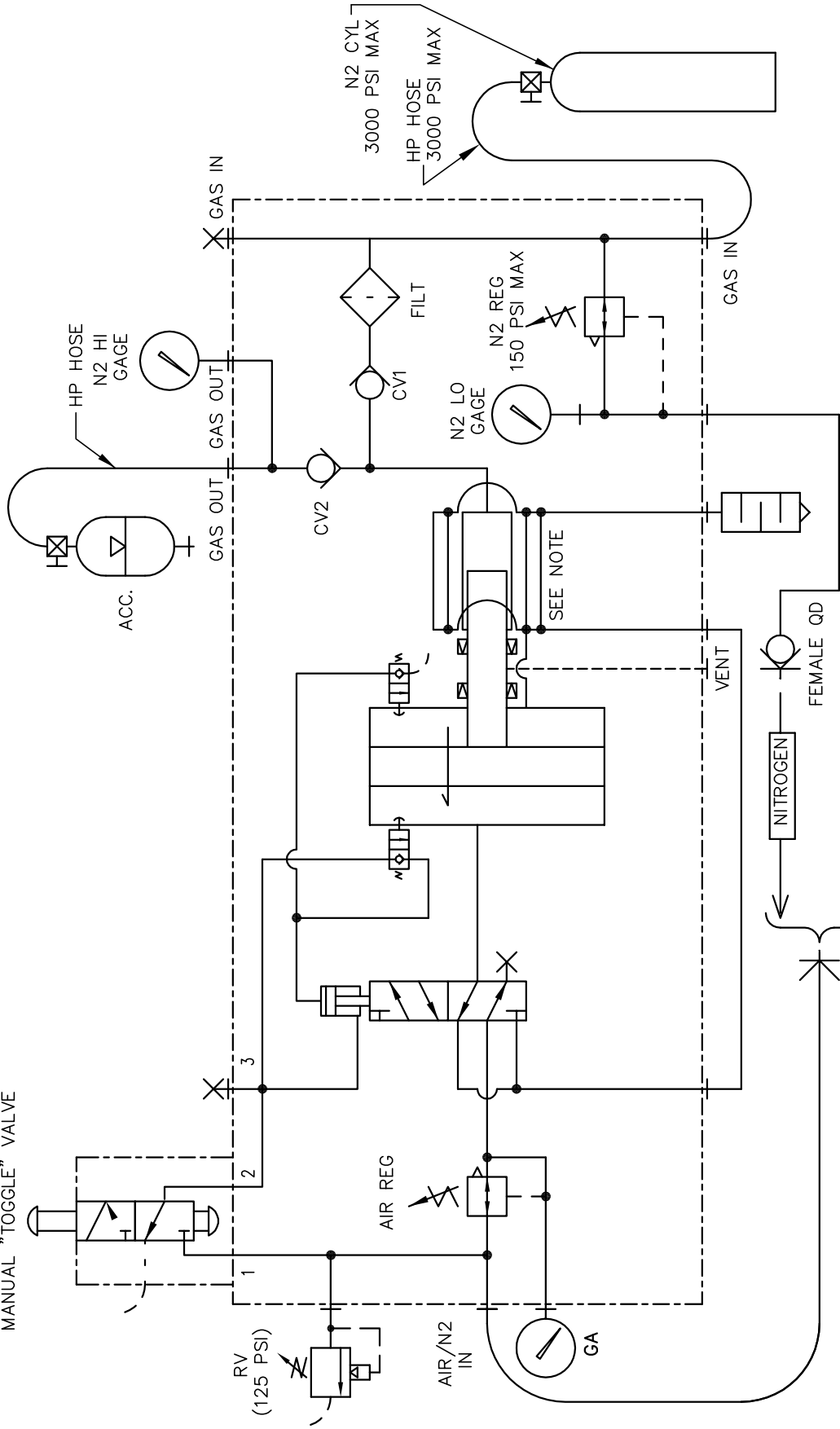

| | | |
|----------------|---|---|
| | | INTERFACE DEVICES, INC. 230 DEPOT ROAD MILFORD, CT 06460 |
| SCALE: N/A | TITLE: PNEUMATIC SCHEMATIC, SA NITROGEN BOOSTER DIRECT CONNECT TO HP CYL. | |
| DWN BY: TWH | REF: | |
| DATE: 10/27/98 | DWG NO: P32-4001 | |
| SHT: 1 OF: 1 | REV: C | |

NOTE: COLD EXHAUST AIR IS ROUTED AROUND THE NITROGEN BORE FOR COOLING

| REV | DESCRIPTION | BY | DATE |
|-----|--|-----|---------|
| K | DEL 42; 45 WAS 10477 P00-5203; 46 WAS SO-9087; 47 WAS 10484 P32-5501 | WNI | 4/30/08 |
| L | ADDED CHART; ADDED IDI P/N'S | WNI | 7/20/10 |
| M | DEL 25 & 34 (INCLUDED W/26) | WNI | 4/13/11 |
| N | ADD IDI P/ANS; REV O-RING MAT'L | WNI | 1/12/12 |

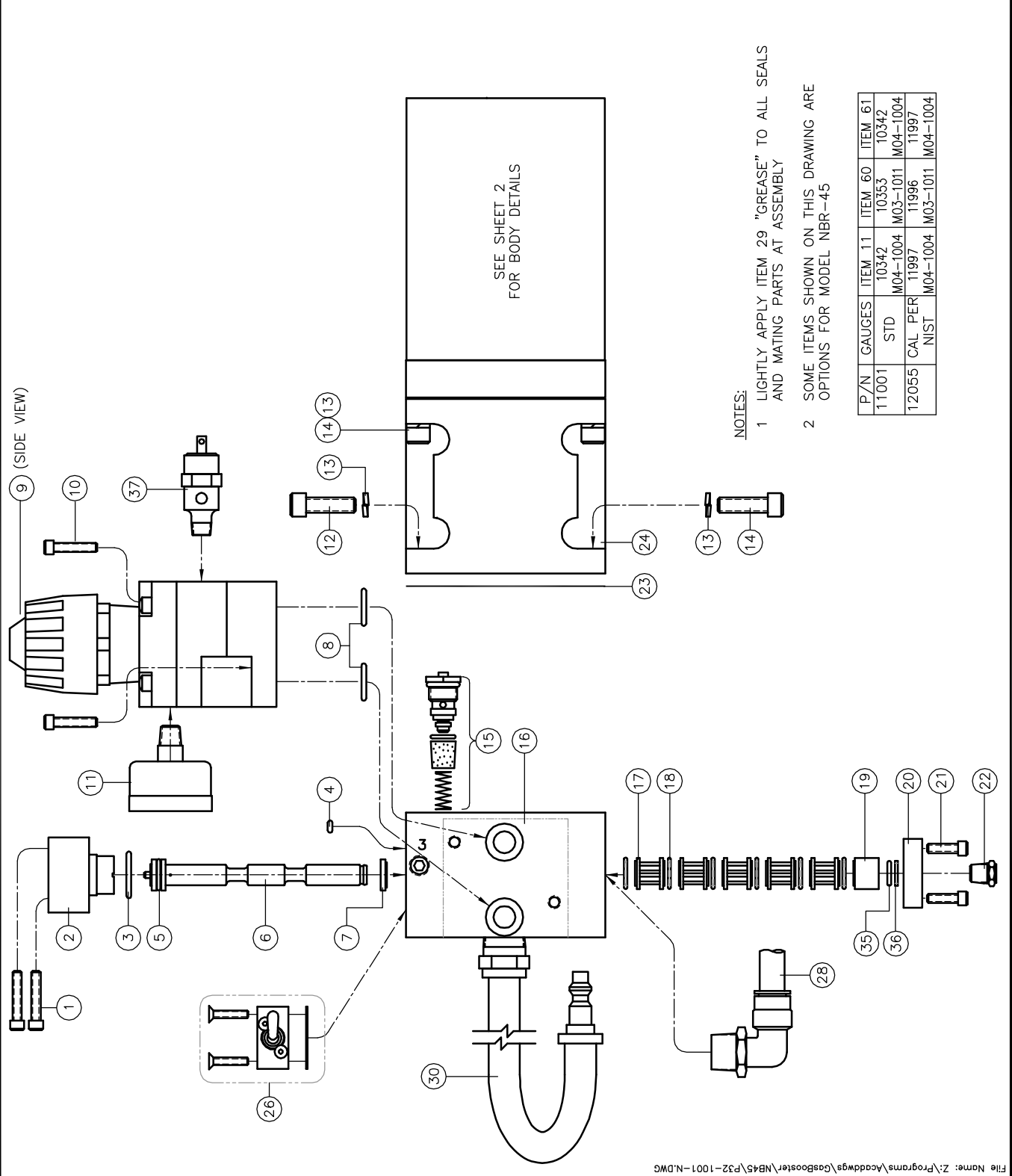

- NOTES:**
- 1 LIGHTLY APPLY ITEM 29 "GREASE" TO ALL SEALS AND MATING PARTS AT ASSEMBLY
 - 2 SOME ITEMS SHOWN ON THIS DRAWING ARE OPTIONS FOR MODEL NBR-45

| P/N | GAUGES | ITEM 11 | ITEM 60 | ITEM 61 |
|-------|---------|----------|----------|----------|
| 11001 | STD | 10342 | 10353 | 10342 |
| 12055 | CAL PER | M04-1004 | M03-1011 | M04-1004 |
| | NIST | 11997 | 11996 | 11997 |
| | | M04-1004 | M03-1011 | M04-1004 |

| ITEM | QTY | PART NUMBER | DESCRIPTION |
|------|-----|----------------|-------------------------|
| 40 | | | |
| 39 | | | |
| 38 | | | |
| 37 | 1 | 11236 M04-1006 | RELIEF VALVE, 1/8 NPT |
| 36 | 1 | 11753 | TEFLON BU RING, -012 |
| 35 | 1 | SO-012P7 | O-RING |
| 34 | | | |
| 33 | | | |
| 32 | | | |
| 31 | | | |
| 30 | 1 | 12060 M03-1046 | HOSE ASSY |
| 29 | A/R | | HOSE, WHITE LITHIUM |
| 28 | 1 | 12061 M04-1025 | HOSE ASSY |
| 27 | | | |
| 26 | 1 | 10743 V04-1001 | VALVE ASSY, 3-W, TOGGLE |
| 25 | | | |
| 24 | 1 | 10111 P12-5202 | BODY, AIR CYLINDER |
| 23 | 1 | 10334 P00-5205 | GASKET, AIR BODY |
| 22 | 1 | 10284 | BREATHER, 1/8 NPT |
| 21 | 2 | 10-24 x .62 | SCREW, SOC HD CAP |
| 20 | 1 | 10289 P00-5208 | SPOOL CAP |
| 19 | 1 | 10269 P00-5210 | BUSHING, LONG |
| 18 | 6 | 10629 | TEE SEAL |
| 17 | 5 | 10273 P00-5209 | CAGE |
| 16 | 1 | 10004 P12-5201 | AIR CAP HOUSING |
| 15 | 1 | 10017 V04-1005 | 2-WAY AIR VLV ASSY |
| 14 | 4 | 5/16-18 x 1.75 | SCREW, SOC HD CAP |
| 13 | 8 | 10393 | WASHER, 5/16 HI COLLAR |
| 12 | 4 | 5/16-18 x 1.00 | SCREW, SOC HD CAP |
| 11 | 1 | SEE CHART | AIR GAUGE (0-160 PSI) |
| 10 | 2 | 1/4-20 x .88 | SCREW, SOC HD CAP |
| 9 | 1 | 10015 P12-1202 | AIR REG ASSY |
| 8 | 2 | SO-016B7 | O-RING |
| 7 | 1 | 10271 P00-5212 | BUSHING, SHORT |
| 6 | 1 | 10659 P00-5211 | AIR SPOOL |
| 5 | 1 | SO-111B7 | O-RING |
| 4 | 1 | SO-006B7 | O-RING |
| 3 | 1 | SO-019B7 | O-RING |
| 2 | 1 | 11768 P00-1202 | PILOT CAP ASSY |
| 1 | 2 | 10-24 x 1.00 | SCREW, SOC HD CAP |

INTERFACE DEVICES, INC.
230 DEPOT ROAD
MILFORD, CT 06460

SCALE: 1/2
DWG BK: WNI
TITLE: ASSEMBLY,
NBR-45 BOOSTER (AVIATION)

DATE: 9/27/99 REF: W/N2 SUPERCHARGE REG.
SHEET: 1 OF 2 DWG NO: P32-1001 REV: N

| REV | DESCRIPTION | BY | DATE |
|-----|--|-----|---------|
| K | DEL 42-45 WAS 10477 P00-5203, 46 WAS SO-903B7, 47 WAS 10484 P32-5801 | WNI | 4/30/08 |
| L | ADDED CHART, ADDED ID: P/NS | WNI | 7/20/10 |
| M | DEL 25 & 34 (INCLUDED W/26) | WNI | 4/13/11 |
| N | ADD ID: P/NS; REV O-RING MAT'L | WNI | 1/12/12 |

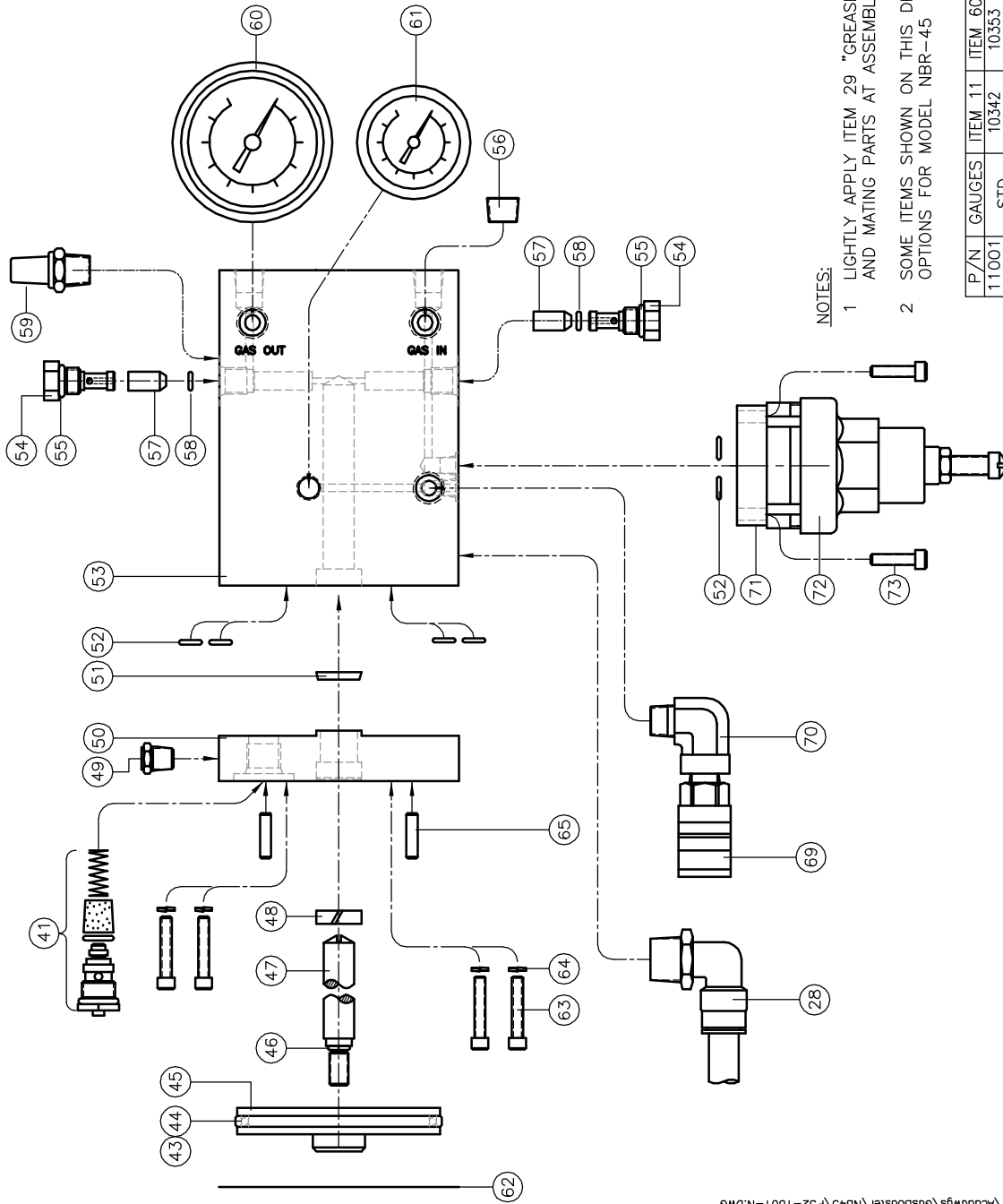

NOT SHOWN

| | | | |
|----|---|----------------|--------------------------|
| 80 | 3 | 1/4-20 x .38 | BUT HD CAP SCR, SS |
| 79 | 1 | 11175 P00-5803 | MOUNTING PLATE |
| 78 | | | |
| 77 | | | |
| 76 | | | |
| 75 | | | |
| 74 | 4 | 10-24 x .75 | SOC HD CAP SCR, SS |
| 73 | 4 | 10-24 x .75 | SOC HD CAP SCR, SS |
| 72 | 1 | 11580 M04-1017 | REGULATOR |
| 71 | 1 | 11562 P32-5604 | REG MTG-BLOCK |
| 70 | 1 | 12011 | STREET ELBOW, 1/4 NPT |
| 69 | 1 | 12058 | QUICK DISCONNECT |
| 68 | | | |
| 67 | | | |
| 66 | | | |
| 65 | 2 | 11772 | DOWEL PIN, .618 x .62 |
| 64 | 4 | 10392 | L'WASHER, 1/4 HI COLLAR |
| 63 | 4 | 1/4-20 x 1.00 | SOC HD CAP SCR |
| 62 | 1 | 10334 P00-5205 | GASKET, AIR BODY |
| 61 | 1 | SEE CHART | GAUGE, 1/8 NPT, CBM, 160 |
| 60 | 1 | SEE CHART | GAUGE, 1/4 NPT, CBM, .5K |
| 59 | 2 | 10429 | MUFFLER, 1/4 NPT |
| 58 | 2 | SO-008P7 | O-RING, POLY |
| 57 | 2 | 10694 M04-1002 | CHECK VALVE (2201) |
| 56 | 1 | 12095 | PIPE PLUG, 1/4 NPT, BRSS |
| 55 | 2 | SO-012P9 | O-RING, POLY |
| 54 | 2 | 11288 P32-5602 | PLUG, CV RETAINER |
| 53 | 1 | 10116 P32-5601 | BODY, N2 BOOSTER |
| 52 | 7 | SO-011B7 | O-RING, BUNA |
| 51 | 1 | 11597 M03-1008 | VARISEAL |
| 50 | 1 | 10553 P32-5401 | RATIO PLATE |
| 49 | 1 | 10284 | BREATHER, 1/8 NPT |
| 48 | 1 | 10369 M03-1031 | ROD BEARING, TEFLON |
| 47 | 1 | 11906 P32-5502 | PISTON ROD |
| 46 | 1 | SO-902B7 | O-RING, BUNA |
| 45 | 1 | 11167 P09-5201 | AIR PISTON |
| 44 | 1 | 10377 | GLYDE RING |
| 43 | 1 | SO-233B7 | O-RING |
| 42 | | | |
| 41 | 1 | 10017 V04-1005 | 2-WAY AIR VLV ASSY |

| ITEM | QTY | PART NUMBER | DESCRIPTION |
|------|-----|----------------|--------------------------|
| 80 | 3 | 1/4-20 x .38 | BUT HD CAP SCR, SS |
| 79 | 1 | 11175 P00-5803 | MOUNTING PLATE |
| 78 | | | |
| 77 | | | |
| 76 | | | |
| 75 | | | |
| 74 | 4 | 10-24 x .75 | SOC HD CAP SCR, SS |
| 73 | 4 | 10-24 x .75 | SOC HD CAP SCR, SS |
| 72 | 1 | 11580 M04-1017 | REGULATOR |
| 71 | 1 | 11562 P32-5604 | REG MTG-BLOCK |
| 70 | 1 | 12011 | STREET ELBOW, 1/4 NPT |
| 69 | 1 | 12058 | QUICK DISCONNECT |
| 68 | | | |
| 67 | | | |
| 66 | | | |
| 65 | 2 | 11772 | DOWEL PIN, .618 x .62 |
| 64 | 4 | 10392 | L'WASHER, 1/4 HI COLLAR |
| 63 | 4 | 1/4-20 x 1.00 | SOC HD CAP SCR |
| 62 | 1 | 10334 P00-5205 | GASKET, AIR BODY |
| 61 | 1 | SEE CHART | GAUGE, 1/8 NPT, CBM, 160 |
| 60 | 1 | SEE CHART | GAUGE, 1/4 NPT, CBM, .5K |
| 59 | 2 | 10429 | MUFFLER, 1/4 NPT |
| 58 | 2 | SO-008P7 | O-RING, POLY |
| 57 | 2 | 10694 M04-1002 | CHECK VALVE (2201) |
| 56 | 1 | 12095 | PIPE PLUG, 1/4 NPT, BRSS |
| 55 | 2 | SO-012P9 | O-RING, POLY |
| 54 | 2 | 11288 P32-5602 | PLUG, CV RETAINER |
| 53 | 1 | 10116 P32-5601 | BODY, N2 BOOSTER |
| 52 | 7 | SO-011B7 | O-RING, BUNA |
| 51 | 1 | 11597 M03-1008 | VARISEAL |
| 50 | 1 | 10553 P32-5401 | RATIO PLATE |
| 49 | 1 | 10284 | BREATHER, 1/8 NPT |
| 48 | 1 | 10369 M03-1031 | ROD BEARING, TEFLON |
| 47 | 1 | 11906 P32-5502 | PISTON ROD |
| 46 | 1 | SO-902B7 | O-RING, BUNA |
| 45 | 1 | 11167 P09-5201 | AIR PISTON |
| 44 | 1 | 10377 | GLYDE RING |
| 43 | 1 | SO-233B7 | O-RING |
| 42 | | | |
| 41 | 1 | 10017 V04-1005 | 2-WAY AIR VLV ASSY |

SCALE: 1/2
 DWG BY: WNI
 TITLE: ASSEMBLY,
 NB-45 BOOSTER (AVIATION)

DATE: 9/27/99 REF: W/N2 SUPERCHARGE REG.
 SHE: 2 OF: 2 DWG NO: P32-1001 REF: N

- NOTES:
- 1 LIGHTLY APPLY ITEM 29 "GREASE" TO ALL SEALS AND MATING PARTS AT ASSEMBLY
 - 2 SOME ITEMS SHOWN ON THIS DRAWING ARE OPTIONS FOR MODEL NBR-45

| P/N | GAUGES | ITEM 11 | ITEM 60 | ITEM 61 |
|-------|---------|----------|----------|----------|
| 11001 | STD | 10342 | 10353 | 10342 |
| 12055 | CAL PER | M04-1004 | M03-1011 | M04-1004 |
| | NIST | 11997 | 11996 | 11997 |
| | | M04-1004 | M03-1011 | M04-1004 |

| REV | DESCRIPTION | DATE |
|-----|--|---------|
| A | ADDED AIR IN RELIEF VALVE | 1/10/03 |
| B | DWG WAS 069001182 A; PICTURE CHANGE MUFFLER 9.9 WAS 10.9 | 3/25/03 |
| C | PICTURE CHANGE: NEW SC REGULATOR | 3/23/05 |
| D | ADDED MTG BRACKET & DIMS | 3/15/12 |

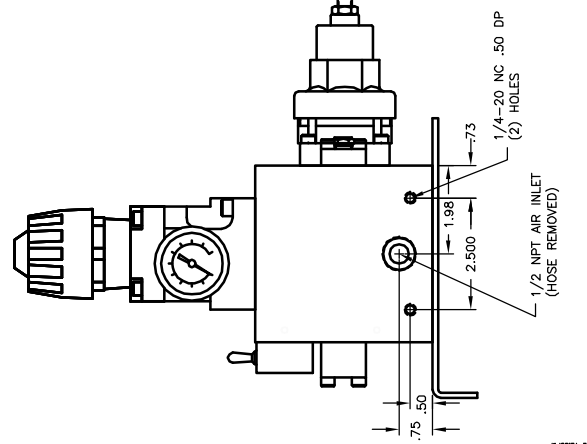
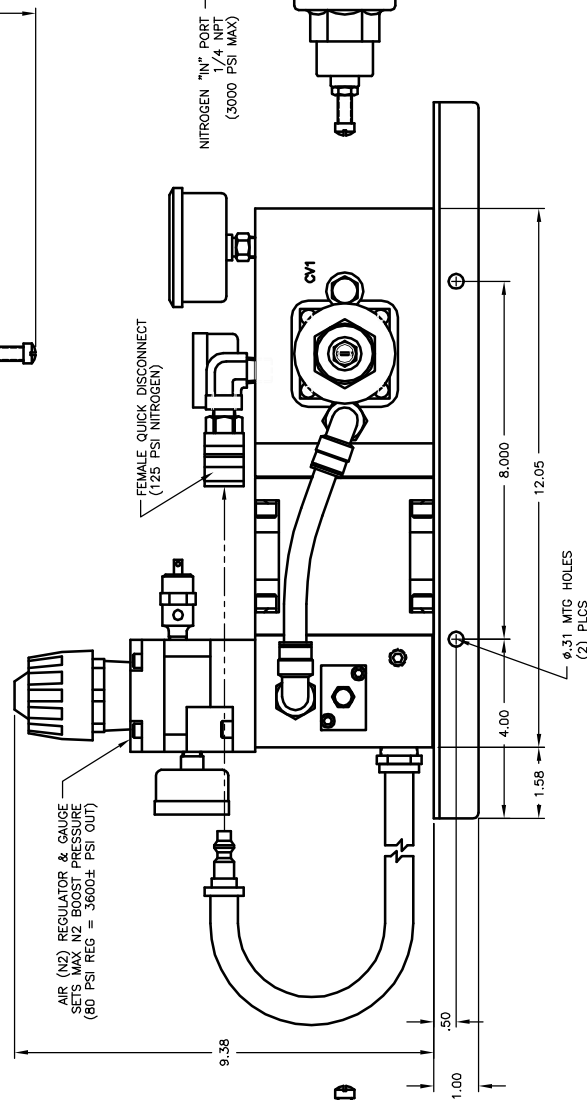
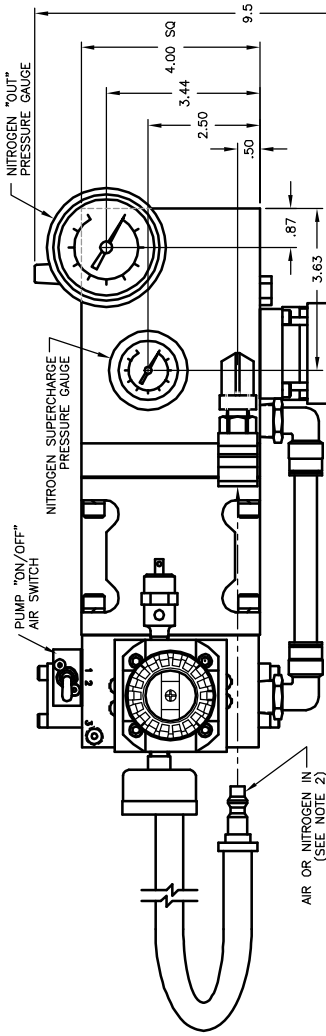

NOTES
 1 SOME COMPONENTS NOT SHOWN IN ALL VIEWS FOR CLARITY
 2 TO RUN PUMP ON SHOP AIR, CONNECT QUICK DISCONNECT TO AIR SUPPLY
 TO RUN PUMP FROM NITROGEN CYLINDER, CONNECT QUICK DISCONNECT TO FEMALE DISCONNECT ON PUMP

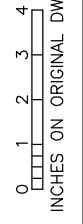

| | | |
|---------|---------|--|
| | | INTERFACE DEVICES, INC. 230 DEPOT ROAD MILFORD, CT 06460 |
| SCALE: | NONE | TITLE: GENERAL ARRANGEMENT, NB-45 BOOSTER (AVIATION) |
| DWG BY: | WNI | |
| DATE: | 1/18/99 | REF: (DIRECT CONNECT TO HP CYL) |
| SHEET: | 1 OF 1 | DWG NO: P32-0001 |
| | | REF: D |